

Energy consumption and conservation in food retailing

S.A. Tassou*, Y. Ge, A. Hadaway, D. Marriott

Doug Marriott Associates, New Forest Farm, New Forest Lane, Chillham, Kent, CT4 6BG, UK

ARTICLE INFO

Article history:

Received 28 February 2010

Accepted 20 August 2010

Keywords:

Supermarkets
Energy consumption
CO₂ refrigeration systems
Opportunities for energy savings
Carbon footprint

ABSTRACT

The total annual CO₂ emissions associated with the energy consumption of the major retail food outlets in the UK amount to around 4.0 MtCO₂. The energy consumption and emissions from supermarkets varies widely and can depend on many factors such as the type and size of the store, business and merchandising practices and refrigeration and environmental control systems used. This paper provides energy consumption data of a sample of 2570 retail food stores from a number of major retail food chains in the UK. The sample covers all major store categories from convenience stores to hypermarkets and includes approximately 30% of the total number of stores in the UK having a net sales area more than 280 m². The data show a wide variability of energy intensity even within stores of the same retail chain. A power law can be used to describe the variation of the average electrical energy intensity of the stores in the sample with sales area. If the electrical intensity of the stores above the average is reduced to the average by energy conservation measures, annual energy savings of the order of 10% or 840 GWh can be achieved representing 355,000 tonnes annual reduction in CO₂ emissions. The paper also discusses the major energy consuming processes in retail food stores and identifies opportunities for energy savings.

© 2010 Elsevier Ltd. All rights reserved.

1. Introduction

Retail food outlets in the UK are responsible for around 3% of total electrical energy consumption and 1% of total GHG emissions. They are characterised by their average sales area and are normally classified as:

- o Hypermarkets - 5000 m² to over 10,000 m² sales area
- o Superstores - 1400 m² to 5000 m²
- o Supermarkets (mid-range stores) - 280 m²–1400 m²
- o Convenience stores including forecourts – less than 280 m².

It is estimated that currently in the UK there are around 6578 supermarkets and superstores of more than 280 m² sales area of which just over 2000 are one-stop shops of more than 1400 m² sales area [1]. Around 1700 of these stores are operated by the four largest supermarket chains, Tesco, ASDA, Sainsbury's and Morrisons. Tesco currently has a commanding market share of around 30.6%, followed by ASDA at 16.3%, Sainsbury's at 16.0% and Morrisons at 11.3%. The remainder 25.8% are shared by smaller chains

such as Somerfield, Waitrose, Iceland, co-ops and other multiple chains and independents.

It is estimated that around £88 billion (or nearly 75 per cent) of sales occurred in stores larger than 280 square metres – that is, stores classified by the Competition Commission as either one-stop shops or mid-sized stores [1]. The remainder £32 billion of sales takes place through more than 50,000 convenience stores. Of these sales 80% is for grocery items and the remainder for non-food products.

The energy consumption of supermarkets will depend on business practices, store format, product mix, shopping activity, the equipment used for in-store food preparation, preservation and display. The electrical energy consumption can vary widely from around 700 k Wh/m² sales area per year in hypermarkets to over 2000 k Wh/m² sales area per year in convenience stores. The refrigeration systems account for between 30% and 60% of the electricity used, whereas lighting accounts for between 15% and 25% with the HVAC equipment and other utilities such as bakery, for the remainder. Gas is normally used for space heating, domestic hot water and in some cases for cooking and baking and will vary from 0 k Wh/m² per year in small stores such as petrol filling stations where gas is not used, to over 250 k Wh/m² per year in hypermarkets. In some stores the gas energy consumption can be as high as 800 k Wh/m² per year.

Retail food stores have significant impacts on the environment. These are indirect emissions through the large amounts of energy

* Corresponding author. Brunel University, Uxbridge, Middlesex UB8 3PH, UK.
E-mail addresses: savvas.tassou@brunel.ac.uk (S.A. Tassou), MarriottUK@aol.com (D. Marriott).

consumption but also direct emissions through refrigerant leakage. Although significant progress has been made in recent years to reduce direct emissions through better system design and leakage sensing, the direct emissions are still significant, as much as 40% of indirect emissions, due to the higher global warming potential of refrigerants employed to replace CFCs and HCFCs.

This paper details the major energy consuming processes in retail food stores and their environmental impacts. Data from monitoring programmes carried out by the authors and information available in the open literature have been used to establish the energy consumption of retail food operations. The paper also outlines current and possible future approaches and technologies for the reduction of energy consumption and emissions.

2. Energy consumption of UK supermarkets

The energy consumption in supermarkets is normally specified in kWh/m² sales area per year and can be defined as the energy intensity of the supermarket. The energy intensity can be used to compare supermarkets that merchandise similar quantities of ambient and refrigerated food products and food and non-food products. Even though convenience stores will normally mainly store core grocery products, supermarkets and superstores in the majority of cases will also merchandise some non grocery products and hypermarkets will devote a significant portion of their sales area to non grocery products, there is no universally accepted definition that characterises energy consumption in terms of product mix.

To characterise the energy consumption of UK supermarkets, a large sample of retail food stores that represents 50% of stores of the main supermarket chains was considered. The data covers close to 50% of stores of the main supermarket chains and it can be safely assumed that the sample is representative of the four main store categories.

Fig. 1 shows the annual electrical energy consumption of 640 convenience stores of sales area between 80 m² and 280 m². The range varies from around 700 kWh/m² per year to 2900 kWh/m² per year which is a factor of four. The wide variability which applies to all the retail food chains considered in the study is mainly due to the business practices employed and equipment used.

The average electrical energy intensity for the sample of 640 stores is 1480 kWh/m² per year and the standard deviation 352 kWh/m² per year. Fig. 1 also shows that the average electrical energy intensity reduces with increasing sales area from around 1700 kWh/m² per year for a sales area of 80 m² to around 1320 kWh/m² per year for a sales area of 280 m². Within the sample, the average electrical energy intensity of the stores using

self contained 'integral' refrigeration equipment was approximately 300 kWh/m² per year higher than the stores using predominantly centrally located 'remote' refrigeration equipment. The standard deviation of these stores was also slightly higher than the remainder of the stores in the sample. Another factor that has an important influence on the electrical energy intensity of convenience stores is the balance between temperature controlled (refrigerated) and ambient products and the balance between frozen and chilled food products.

Fig. 2 shows the electrical energy intensity of 1360 stores of sales area between 280 m² and 1400 m². The average electrical energy intensity of these stores varies from 1500 kWh/m² per year down to 850 kWh/m² per year as the sales area increases from 280 m² to 1400 m². For the same sales area range, the range in the electrical energy intensity also reduces significantly, from around 1600 kWh/m² per year down to 1000 kWh/m² per year. The reduction in the average electrical energy intensity for all stores in the sample is 1000 kWh/m² per year and the standard deviation 220 kWh/m² per year.

The electrical energy intensity of 420 stores with sales area in the range 1400 m²–5000 m² is shown in Fig. 3. Again it can be seen that the range in the electrical energy intensity reduces from around 1000 kWh/m² per year to 600 kWh/m² per year as the sales area increases from 1400 m² to 5000 m². The average electrical energy intensity in this sample only reduces slightly with sales area. The average of all stores in the sample is 920 kWh/m² per year and the standard deviation 140 kWh/m² per year.

Fig. 4 shows the electrical energy intensity of 150 stores with sales area in the range 5000–10000 m². The range of the electrical energy intensity data reduces from around 600 kWh/m² to 220 kWh/m² as the sales area increases from 5000 to 10000 m². For the same sales area range, the average electrical energy intensity reduces from around 870 to around 660 kWh/m². The average electrical energy consumption in this range is 770 kWh/m² and the standard deviation 120 kWh/m².

Fig. 5 shows the electrical energy intensity of all 2570 stores considered in the study. The variation of the average electrical energy intensity with sales area is shown by the solid curve on the graph and can be described by the following equation.

$$W_e = 3600 \times A_s^{-0.18}$$

Where:

W_e = Electrical energy consumption per unit sales area (kWh/m²)

A_s = Sales area (m²)

It can be seen that for convenience stores and supermarkets up to a sales area of around 1400 m² the electrical energy intensity

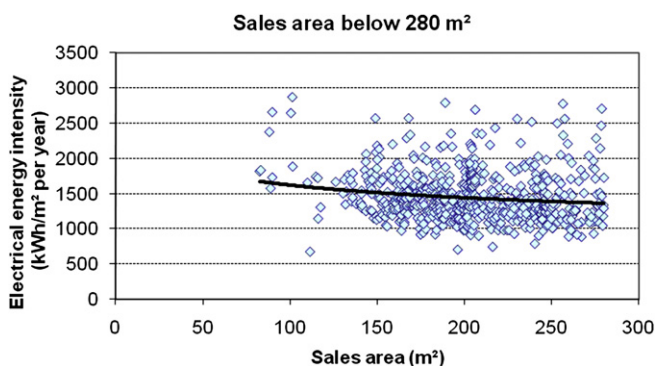

Fig. 1. Electrical energy intensity of convenience stores of sales area between 80 m² and 280 m²

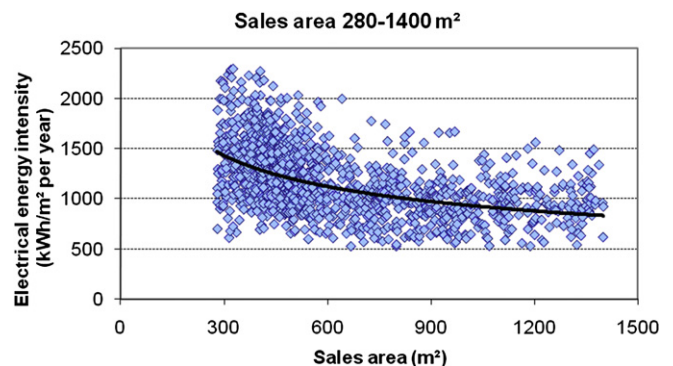

Fig. 2. Electrical energy intensity of supermarkets of sales area between 280 m² and 1400 m²

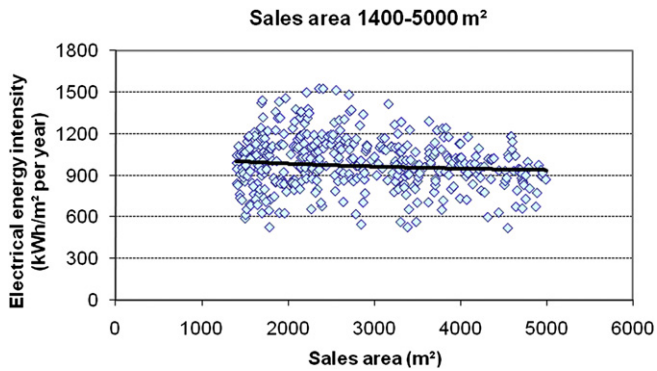

Fig. 3. Electrical energy intensity of supermarkets of sales area between 1400 m² and 5000 m²

drops exponentially. This is due to the shift from food dominant to non-food dominant sales operations and a reduction in the refrigeration energy consumption per unit sales floor area. Above 2000 m² sales area, the drop in electrical energy intensity with increasing sales area becomes very small as the impact of refrigeration on the total energy consumption reduces and that of artificial lighting becomes more significant.

For the smaller size food dominant stores, the wide variation in electrical energy intensity between stores indicates that significant energy savings per unit floor sales area can be achieved if the energy consumption, particularly that due to refrigeration is reduced to the average of the sample of each store category. If the electrical energy intensity of the stores whose intensity is above average is reduced to the average by retrofit measures annual energy savings of the order of 10% (310 GWh) can be achieved.

Table 1 shows estimates of electrical and gas consumption data and corresponding greenhouse gas emissions from the retail food operations of the 10 largest retail food chains in the UK. The data refer to the retail food stores alone and do not include Regional Distribution Centres (RDCs) and transport energy consumption. The estimates are based on actual data for the 2570 stores considered in this study and energy data published by the major chains. The CO₂ emissions are indirect emissions from energy consumption alone and do not include emissions from refrigerant leakage.

3. Energy consuming processes and greenhouse gas emissions of supermarkets

The environmental impacts of supermarkets are normally quantified in terms of greenhouse gas emissions. These emissions arise from the following operations and waste streams:

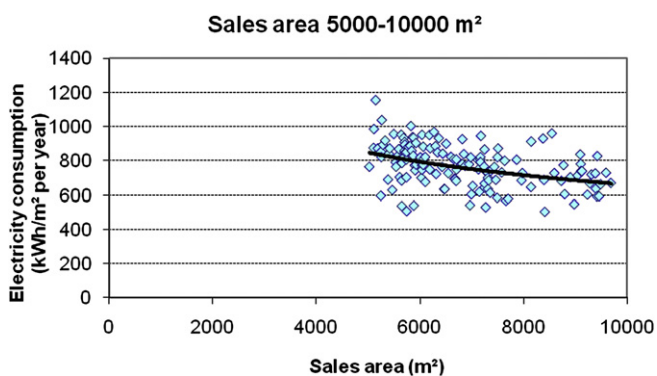

Fig. 4. Electrical energy intensity of supermarkets of sales area between 5000 m² and 10000 m²

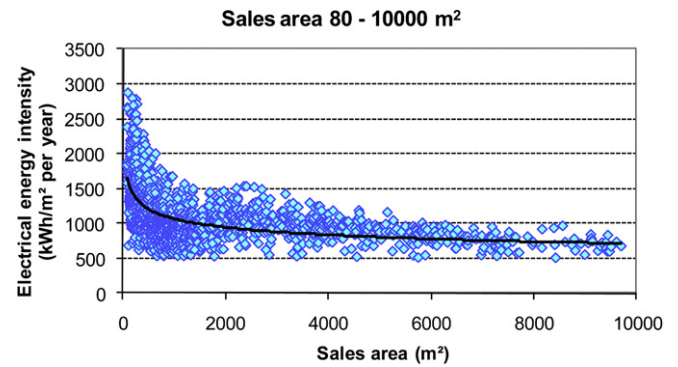

Fig. 5. Variation of electrical energy intensity of 2570 UK retail food stores with sales area from 80 m² to 10,000 m²

i) Energy Consumption and indirect emissions

In UK supermarkets, more than 70% of the energy consumed is electricity the majority of which is used to drive the refrigeration equipment in the store. The remainder is used for lighting, HVAC (heating ventilation and air conditioning) baking and other ancillary services. Retail food stores will also use gas for space and domestic hot water heating, and sometimes for baking.

Fig. 6 shows the percentage contribution of the various electrical energy consuming processes in a hypermarket. It can be seen that energy consumed by refrigeration is the largest component followed by lighting in the store, bakery, HVAC and other ancillary services which include restaurants, external lighting etc. Smaller supermarkets and convenience stores will not have many of the ancillary services and the proportion for refrigeration will be higher.

i) Direct emissions from refrigerants

Refrigeration systems in supermarkets contain substantial amounts of refrigerant. Some refrigerants are potent greenhouse gases and their impact is characterised by their Global Warming Potential. Although significant progress has been made in recent years to reduce refrigerant leakage and direct GHG emissions through better system design and leakage sensing, the direct emissions are still significant, and sometimes can exceed indirect emissions.

iii) Other emission streams

These include GHG emissions from plastic shopping bags food waste, packaging and other waste such as waste water and cooking oils. The level of these emissions are depended on the waste management options employed but are normally small compared to emissions due to energy consumption and refrigerant leakage.

Figs. 7 and 8 show the percentage GHG emissions from the distribution and retail phase of the product life cycle of chilled packed meat and frozen peas respectively. The calculation of emissions from refrigerant leakage is based on an assumption of R404A refrigerant and 15% refrigerant leakage rate.

It can be seen that for both the chilled and frozen food, refrigeration accounts for more than 85% of the emissions determined per kg of food product. The other emissions are very small by comparison. The plastic bags considered in the analysis are the carrier bags only and not the plastic packaging of the product. The difference between the plastic bag contribution of the packed meat and frozen peas is due to the difference in the total quantity of emissions from the two products which is almost double for the latter.

Table 1
Annual energy consumption and greenhouse gas emissions of 10 major UK retail food chains.

| | Supermarket Electrical Energy Consumption (GWh) | Gas Energy Consumption (GWh) | CO ₂ Emissions Electrical Power (tonnes) | CO ₂ Emissions Gas (tonnes) | Total CO ₂ Emissions (tonnes) |
|--------------------------------|---|------------------------------|---|--|--|
| 10 major UK retail food chains | 8385 | 2477 | 3538470 | 470630 | 4009100 (4.01 MtCO₂) |

4. Approaches to reduce the environmental impacts of refrigeration systems

Refrigeration systems in supermarkets are commonly of the remote type where the evaporator or cooling coils within the display fixtures in the store are served by refrigeration equipment located remotely in a plant room. The evaporators in the refrigerated display fixtures and cold rooms are fed with refrigerant from the central plant through distribution pipework installed under the floor or along the ceiling of the sales area. In the plant room, multiple refrigeration compressors, using common suction and discharge manifolds are mounted on bases or racks normally known as compressor ‘packs’ or compressor ‘racks’ which also contain all necessary piping, valves, and electrical components needed for the operation and control of the compressors. Air-cooled or evaporatively cooled condensers used in conjunction with the multiple compressor systems are installed remotely from the compressors, usually on the roof of the plant room.

Normally separate compressor packs are used for chilled and frozen food applications. Most large supermarkets will have a number of packs to serve the chilled food cabinets and one or two packs to serve the frozen food cabinets. A major disadvantage of the centralised DX system is the large quantity of refrigerant required, 4–5 kg/kW refrigeration capacity and the large annual leakage rates of between 10% and 30% of total refrigerant charge. One way of reducing significantly the refrigerant charge in supermarket refrigeration systems is to use a secondary or indirect system arrangement. With this arrangement, a primary system which can be located in a plant room or the roof and can use natural refrigerants such as hydrocarbons or ammonia, cools a secondary fluid which is circulated to the coils in the display cabinets and cold rooms. Separate refrigeration systems and brine loops are used for the medium and low temperature display cabinets and other refrigerated fixtures.

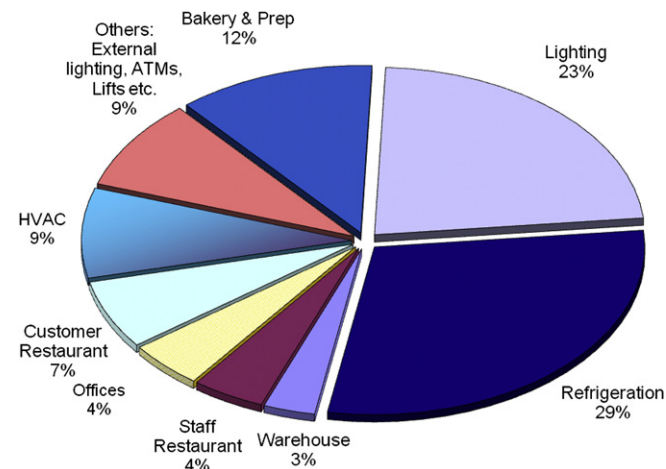

Fig. 6. Percentage contribution of electrical energy consuming processes in a hypermarket.

There are two types of secondary fluids, single phase and two phase. The most common are single phase, but none is ideal for application in both the medium and low temperature loops. For medium temperature loops the most common fluids are propylene glycol/water and for low temperature loops solutions of potassium formate/water [2–4]. Two-phase secondary refrigerants offer the advantage of the high latent heat during the phase change process from solid to liquid and from liquid to vapour. Examples of two phase fluids that have been applied or investigated in recent years are ice slurries, hydrate slurries and CO₂ [5–7]. CO₂ is a natural refrigerant with a negligible Global Warming Potential and very good thermodynamic properties which has attracted significant interest in recent years as a potential replacement of HFC refrigerants [8]. Most of the early development work of CO₂ systems for supermarket refrigeration applications has taken place in Scandinavia but now their application is spreading across Europe, North America and Australia.

4.1. CO₂ refrigeration systems

CO₂ apart from its negligible Global Warming Potential, offers a number of other advantages over HFC refrigerants which include better heat transfer performance, and smaller components for a given refrigeration load. The main disadvantages of CO₂ are its high saturation pressures and its very low critical temperature of 31.1 °C, compared to 72 °C for R404A and 96 °C for R22 [9]. This means that even at relatively low ambient temperatures the system operates above the critical point on the high pressure side. Condensation of the refrigerant after compression is no longer possible in the high pressure heat exchanger. The heat exchanger only sensibly cools the refrigerant and so it is referred to as a ‘gas cooler’. The change of phase of the refrigerant from vapour to a mixture of liquid and vapour takes place during the expansion process from the gas cooler pressure to the evaporator pressure. This cycle is known as the transcritical cycle and in its simpler form

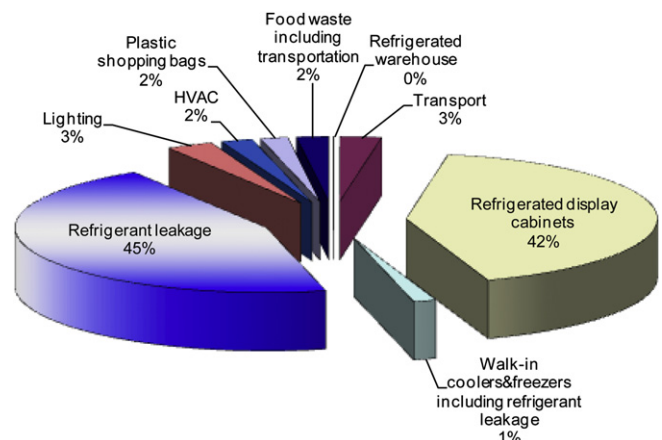

Fig. 7. Percentage contributions to total GHG emissions for Fresh Packed Meat.

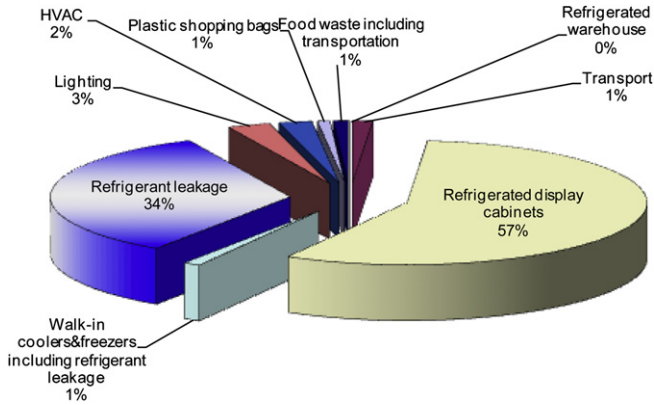

Fig. 8. Percentage contributions to total GHG emissions for Frozen Peas.

has a lower efficiency than equivalent single stage cycles for HFC refrigerants such as R404A.

To avoid the difficulties with high pressures and transcritical operation, early CO₂ refrigeration systems for supermarket applications were designed to operate subcritically in either a secondary refrigeration system arrangement where CO₂ was used as a secondary refrigerant or in a cascade arrangement. In cascade systems, different arrangements can be implemented for CO₂ condensation [10]. Some of these systems, particularly in Northern Europe use natural refrigerants such as ammonia and propane for condensation of the CO₂ and heat rejection to the ambient [11,12], Fig. 9, but in a large number of installations R404A is still employed. The R404A charge in the system is however significantly smaller than in all R404A systems.

A disadvantage of cascade systems that employ two different refrigerants is the complexity of the installation and requirement of servicing of two different systems with different components and lubrication oils. CO₂ transcritical systems enable the use of a single refrigerant, for both the low and medium temperature refrigeration requirements in the store. This should simplify system installation but the high pressures involved in the system, 90 bar or above, impose specific design, control and safety challenges. In the last six years a number of different all CO₂ design alternatives have emerged which are being applied to different store sizes and climates in Europe, Australia and North America. A schematic diagram of an all CO₂ cascade system is shown in Fig. 10 and the P-h diagram of the medium temperature refrigeration circuit operating in the transcritical mode is shown in Fig. 11. One of the first such systems was installed by Linde in a large supermarket in Wettlingen, Switzerland [13]. The system consists of three separate circuits, two for medium temperature (320 kW) and one for the low temperature requirements of the supermarket (50 kW). The performance of the system was expected to be better than R404A, and have lower power consumption per unit cooling capacity, at ambient temperatures below 14 °C and worse at ambient temperature above 28 °C. The performance of the CO₂ medium temperature system can be improved at high ambient temperature through the use of evaporative cooling. The capital cost of the system was found to be higher than the capital cost of R404A systems due to the higher cost of the major components which were prototype developments. As such, the cost of the system is likely to reduce through wider application and mass production of components.

A similar approach is now being followed by Tesco in their development of CO₂ technology in collaboration with Star Refrigeration to suit both new and retrofit store applications. The system design is based on a modular approach where standard low temperature packages are cascaded with two or three high

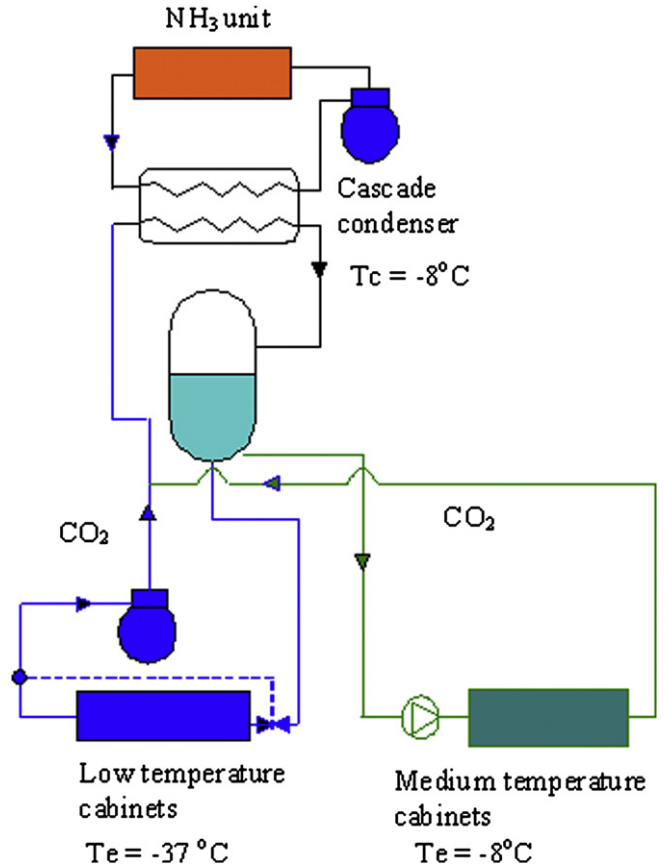

Fig. 9. Schematic diagram of NH₃/CO₂ cascade system with CO₂ at the medium temperature and low temperature levels.

temperature packages to suit a wide range of loads and store formats [14].

A system design that is gaining in popularity, particularly for smaller store applications is the transcritical ‘booster’ system [15,16]. A number of variations in system design are possible but the most developed at present is the ‘booster’ system with

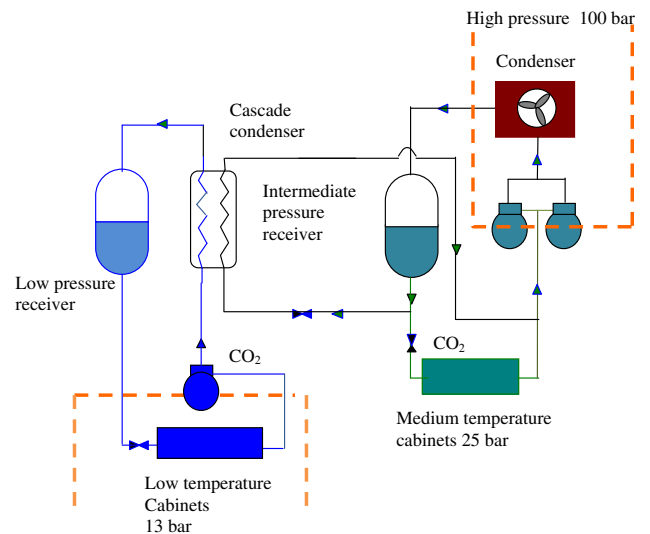

Fig. 10. Schematic diagram of all CO₂ cascade system.

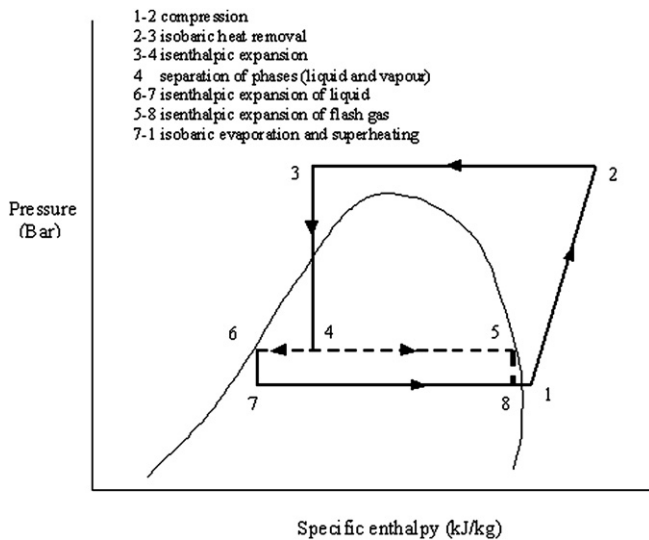

Fig. 11. P-h Diagram of medium temperature transcritical CO₂ system.

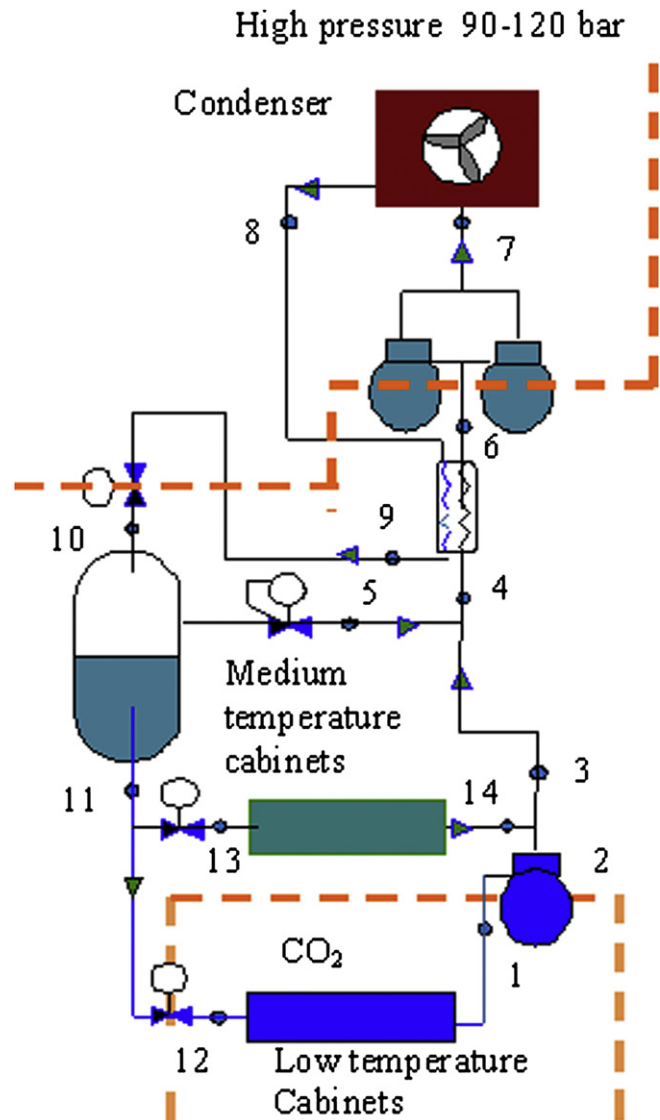

Fig. 12. Booster system with gas by-pass.

gas-bypass. A schematic diagram of the system is shown in Fig. 12 and the corresponding P-h diagram in Fig. 13. With this system, there is no cascade condenser. Instead, the gas from the low stage compressors flows to the high stage compressors after it mixes with superheated vapour from the medium temperature evaporators and flash gas from the receiver. Booster systems are simpler in design and require lower number of components than cascade systems so they may be more suitable for smaller supermarkets.

In summary, CO₂ refrigeration systems for supermarket applications are still in the early stages of development compared to the period of development of HCFC and HFC refrigeration systems. Results to date indicate that their performance for low temperature food refrigeration applications in a cascade arrangement where the CO₂ system operates in the subcritical region is superior to R404A direct expansion systems. Operation of CO₂ systems in the transcritical range has been found to be less efficient compared to R404A systems, particularly for heat rejection at high ambient temperatures. The cost of CO₂ systems has been found to be between 10% and 30% higher than the cost of R404A systems due to the higher pressures and specialist components and controls required but this cost is expected to reduce as components become standardised and mass produced with expansion of the market. The higher temperatures available for heat rejection in the gas cooler of CO₂ systems provides opportunities for heat recovery and the use of the heat for heating or desiccant cooling which increases their attractiveness over HFC refrigeration systems.

In the UK the interest in natural refrigerants, particularly CO₂ is increasing with a number of the large supermarket chains committing to CO₂ technology in their strife to become carbon neutral in the future.

4.2. Conventional centralised refrigeration systems

In conventional multi-compressor refrigeration systems in supermarkets compressors account for around 60% of the total energy used for refrigeration and 30% of the total electrical energy consumption of the store. In recent years the trend has been towards the use of scroll compressors due to their lighter weight and ease of replacement by maintenance engineers in the event of failure. The efficiency of scroll compressors has increased in recent years and is now comparable to that of semi-hermetic compressors particularly during operation at low pressure ratios.

Irrespective of the type of compressor employed, energy savings can be achieved through better matching of the compressor capacity to the load by on-off cycling or variable speed control and the minimisation of the pressure differential across the compressors through condensing (head) and evaporating (suction) pressure control. Head pressure control is now well established with the condenser pressure allowed to float in response to the variation in the ambient temperature. Energy savings for variable head pressure control over fixed head pressure control can be between 20% and 30% of the energy consumption of the compressors [17].

Head pressure control limits opportunities for heat recovery from desuperheating the compressor discharge gas however, and the relative economic and environmental benefits of the two strategies should be re-examined. A way to benefit from heat recovery and low head pressure may be to employ heat rejection to water and use ground cooling instead of air cooling and a heat pump to upgrade the reject heat for heating and hot water purposes. Suction pressure control which can lead to energy savings of the order of 10% compared to fixed suction pressure is not widely applied as yet, due to greater control complexity and the requirement to maintain product temperature in all refrigerated cabinets whilst adjusting the suction pressure.

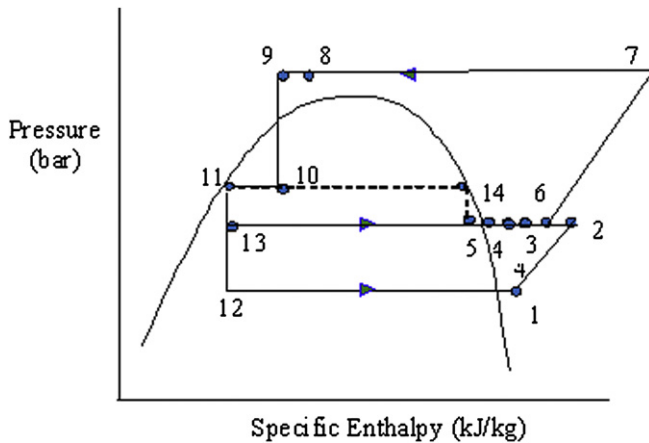

Fig. 13. P-h diagram of booster system.

4.3. Refrigerated display cabinets

The cooling load of refrigerated cabinets determines the load on the refrigeration compressors. The load on the cabinets at steady state conditions is mainly due to heat transfer between the fabric of the cabinet and the ambient air (conduction and convection) radiation between the products in the cabinet and the surrounding surfaces, internal gains from fans and lights and infiltration. Infiltration arises from air exchanges between the cabinet and the surrounding environment. Typical contributions of the various heat transfer elements to the load of an open front integral multi-deck chilled food refrigerated cabinet is shown in Fig. 14 [18]. These contributions will vary with the cabinet type, the cabinet design and the operating and control conditions. For example the contribution of infiltration will be much higher for open multi-deck display cabinets compared to frozen food well or frozen glass door reach-in cabinets.

Ways of reducing the infiltration load for open multi-deck cabinets are: to improve significantly the performance of air curtains used to reduce ambient air infiltration into the cabinet, the use of night blinds during periods when the store is closed or the use of glass doors.

Significant research has been carried out to improve the performance air curtains in recent years. This included both experimental studies and modelling using Computational Fluid Dynamics [19–21]. The majority of these studies have been carried

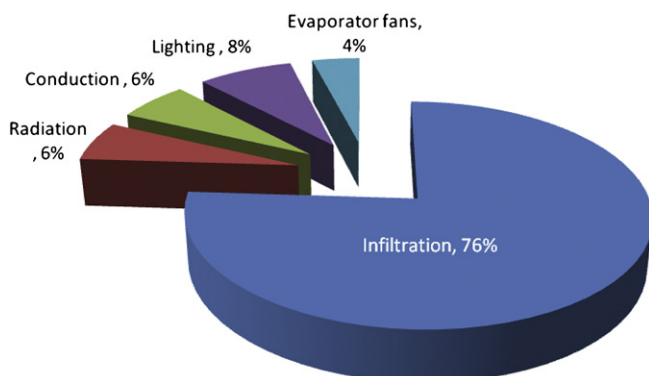

Fig. 14. Contributions to the load of a vertical multi-deck open front chilled food display cabinet.

out on specific cabinets and the results have not been generalised, even though some generic principles have been established. A major study funded by the US Department of Energy aimed to develop an understanding of the infiltration phenomenon, the key variables affecting infiltration and develop a design tool to predict infiltration in display cabinets [22].

The results indicated that for the cabinet considered a reduction in infiltration of up to 18% could be achieved if a number of design principles were applied [22].

Energy savings through the use of night blinds are a function of the ambient temperature, the quality of the blind and its fitting on the cabinet and the on-off operational cycle of the blind. The use of night blinds has been found to generate energy savings of up to 20% but their use has been mainly concentrated on stand alone cabinets in smaller food retail outlets [23]. Night blinds are not normally employed in 24 h trading stores and are also not popular with larger stores as they are considered to interfere with cabinet loading during the night. The use of glass doors on chilled food vertical multi-deck display cabinets has been shown to produce refrigeration energy savings of the order of 50% [24]. Although the use of glass doors on frozen food cabinets is now widely practiced, there is reluctance to their wide implementation to chilled cabinets in large supermarkets due to concerns on their potential impact on sales.

The internal loads of cabinets from fan gains which are proportional to the energy consumed by the fan can be reduced by using more efficient fans (aerodynamic blades on axial flow fans) and more efficient fan motors such as ECM (Electronically Commutated Motors). ECMs have been shown to produce 67% energy savings over conventional shaded pole motors [25]. ECMs are more expensive than conventional motors and the use of tangential fans in the place of axial fans can reduce the number of fans required. A problem with tangential fans is that they are more difficult to clean in comparison to axial flow fans. Internal loads from lighting can be reduced through the use of more efficient lighting fixtures and electronic ballasts as indicated in Section 5.2.

Efficiency improvements can also be achieved through the use of more efficient evaporator coils. An efficient coil will lead to an increase in the evaporating temperature and pressure and will lead to a reduction in the compressor power consumption [26]. The need to maintain a certain evaporator coil air off temperature to satisfy the cooling needs of the displayed products imposes a limit on the maximum possible evaporation temperature and efficiency gains that can be achieved through the heat transfer enhancement of evaporator coil performance. Other important issues to be considered are pressure drop on the coil that increases the fan power, and frosting and defrosting losses. Depending on the coil design and environmental conditions it is possible to defrost the coils of chilled food display cabinets using off-cycle defrost. With this defrost method the refrigerant supply to the evaporator is switched off and defrost is achieved by circulating cabinet air through the coil. The temperature of this air increases with infiltration of ambient air from the surroundings and melts the ice accumulated on the coil.

The evaporator coils of frozen food cabinets cannot be defrosted by off-cycle defrost alone and electric defrost is employed in the majority of cases. Defrost of frozen food cabinets is normally effected at between six and 12 hourly intervals, depending on the refrigerated fixture. Experience has shown that the defrost frequency may be excessive for the majority of operating conditions and this penalises system performance. Defrost energy savings can be achieved using defrost on demand [27,28]. It has been demonstrated that using defrost on demand on full glass door frozen food cabinets can achieve energy savings of the order of 12% [29].

5. Indoor environmental control systems in Supermarkets

5.1. HVAC systems

Supermarkets present a unique space conditioning challenge because of the interaction between the HVAC system and the refrigerated display cases. The display cases provide significant sensible cooling and increase the latent load fraction on the HVAC system. To-date in the UK, however, for traditional reasons and the way that the two industries developed over the years, the two systems are controlled mostly independently.

The energy consumption of the HVAC systems (heating, ventilation and cooling) in retail food stores can be between 15% and 25% depending on the system design, geographic location and controls. Although different types of systems and approaches have been tried over the last few years to improve thermal comfort and reduce energy consumption, such as underfloor heating, displacement ventilation and natural ventilation, the most common system nowadays is the all air constant volume system. This system provides ventilation, heating and cooling in the store by conditioning air in the central plant and providing it through overhead distribution ductwork to different parts of the store. Return air ducts return the air to the air handling unit(s) where part of it is mixed with fresh air and returned to the store whereas the rest is discharged to the atmosphere. In supermarkets, however, significant infiltration takes place through the high traffic doorways and this will reduce the fresh air requirements. These doorways are normally protected using air curtains or automatic doors and in some new supermarkets a combination of a lobby area with automatic doors, leading to a second set of doors protected by air curtains. Even with these arrangements, however, infiltration will still have an impact on the HVAC load (both heating and cooling) and the fresh air requirement through the mechanical ventilation systems.

Considerable opportunities exist to reduce the energy consumption of HVAC systems in retail food stores which can also have a positive impact on the reduction of the energy consumption of the refrigeration systems. More sophisticated design and control strategies can be used to allow for free cooling when the outdoor temperature is lower than the store air set point temperature. Other strategies that can be adopted is to use demand controlled ventilation using CO₂ measurements or other control parameters such as shopping activity to control the amount of fresh and total air supplied using variable speed fans. Heat recovery systems can also be employed to utilise heat rejection from the refrigeration plant and bakery ovens for space and water heating. To facilitate heat recovery and at the same time allow the use of floating condensing pressure control, the use of heat pumps can be considered.

Air overspill from open display cabinets which leads to the 'cold aisle' effect can be used to provide cooling in other parts of the store. At least one major retailer, in its new stores, recovers part of this air and returns it to the air handling unit for recirculation to the store in the summer. Although this can reduce the 'cold aisle' effect should theoretically lead to energy savings there may be other more effective approaches to control the local aisle environment that could lead to both energy savings and reduction of refrigeration energy consumption and emissions [30].

Other approaches for energy conservation in HVAC systems is to use variable space temperature set-points based on the outdoor temperature and better zonal control to provide low levels of humidity (moisture content) close to the refrigerated display cabinets to reduce frosting and defrosting losses and energy input to anti-sweat heaters.

5.2. Lighting

Lighting plays an extremely important role in attracting customers in the food retail industry. In supermarkets, lighting design requires different approaches in the various departments: refrigerated display cases, bakery, meat, produce, and general packaged foods. In addition, lighting of the entryway needs to be attractive to the customer and the checkout area must provide enough light to make the sales transactions easy. In general, supermarkets in the general sales area are designed for high lighting levels, around 1000 lux or even higher, as there is a belief that bright light is generally attractive to customers [31]. Accent lighting is also provided in many cases to highlight particular products and displays.

Lighting is a major consumer of energy in supermarkets, and depending on the age of the store and lighting fixtures used, lighting can account for between 15% and 30% of electrical energy consumption. The majority of lighting fixtures in stores use fluorescent lighting. Older stores may use T12 fluorescent tubes but newer stores will have T8 tubes. Nearly all commercial refrigerated cabinets use linear fluorescent lamps. Although fluorescent lamps may provide superior energy efficiency in many lighting applications, their use in commercial refrigeration is not ideal. Fluorescent lamps in this application exhibit a reduced light output of up to 25% and uneven lighting on the products. These problems are a result of ineffective lamp operation at cold temperatures, and poor configuration and mounting location within the cabinets.

A number of new supermarkets have been designed to maximise daylighting through:

- Light pipes mainly in the office areas.
- The store façade at design stage.
- Glazed parts of the roof introduced at the design stage.

Analysis using a case study in a recently energy efficient store employing design features for the utilisation of solar energy in the form of daylighting has shown that there is significant potential to reduce energy consumption in retail food stores through the use of daylighting, up to 25% of lighting energy requirements [32]. The main barriers to the wider application of daylighting, however, is the requirement to satisfy the new building regulations in terms of the overall thermal performance of the building fabric, the high cost of the first store design to incorporate daylighting and the requirement to have consistent levels of illumination on certain types of food and non-food products. Integration of daylighting with artificial lighting should be able to satisfy both energy and merchandising requirements at acceptable additional capital cost but detailed research and development is required to reduce the impacts and maximise the benefits of daylighting.

For stores operating late at night or 24 h stores, dual level switching for overhead lighting fixtures can be employed, allowing alternate fixtures to be turned off during low-traffic hours. Further lighting energy reduction can be achieved through:

- the installation of occupancy sensors to reduce lighting in storage rooms, back-of-house offices, and other vacant or low-traffic areas.
- upgrading to more efficient lighting technologies, including replacement of T-12 and T-8 with T-5 fixtures.
- switching from high pressure sodium lamps to metal halide lamps in car parks and upgrade to LED lighting for outdoor signage.

In recent years, there has been considerable developments in LED lighting to the level that they are now becoming competitive

with fluorescent lighting in glass door freezer cabinets. LEDs have the potential to provide more uniform lighting levels in the cabinet, very long life (up to 50,000 h) and energy savings that as yet have not been quantified in service applications. A number of retailers are currently trialling LED lighting for glass door freezer cabinets and other applications [33] which are expected to produce up to 66% energy savings over conventional fluorescent lighting fixtures [34].

5.3. Building fabric and use of renewable energy sources

New supermarket designs have to comply with the new Part L building regulations with respect to their overall insulation, air tightness and heat transmittance but also they have to incorporate renewable energy technologies to satisfy 10% of their energy requirements. The definition of renewable energy sources in this context is quite broad and incorporates a number of technologies such as solar electricity (PV), solar thermal, wind energy, heat pumps, biomass, geothermal heating and cooling, Combined Heat and Power (CHP). Many of these technologies are currently under assessment by a number of major retailers and researchers [32].

With current energy prices and absence of legislation to make mandatory a much higher percentage of CO₂ reduction in supermarkets from the use of renewables, reduction of the energy consumption of refrigeration equipment and artificial lighting are much more economically attractive to retailers than wider application of renewable sources. However, as the potential to increase further refrigeration and lighting efficiency at reasonable cost is exhausted, further reduction of the carbon footprint of supermarkets and other food facilities could be achieved through:

- i) better integration and control of current and emerging technologies;
- ii) technological developments and radical approaches to merchandising;
- iii) improvement of the performance of renewable technologies and their optimum integration within the building structure, for example, application of transparent PV modules into appropriately oriented supermarket façades to replace conventional glazing. Consideration should be given to potential reduction of structural costs over conventional roof mounted PVs; impact on daylighting; integration of daylighting and artificial lighting to achieve required lighting levels at minimum running costs.
- iv) evaluation and integration of renewables such as solar, wind, biomass and other low carbon technologies such as CHP, tri-generation, ground source heat pumps within the context of overall thermal energy management and environmental control of the food facility.

5.4. Demand side management and system integration

Most large retail food stores are, for some years now, equipped with central monitoring and control systems to primarily satisfy food hygiene regulations. These systems monitor and control the temperature in the refrigerated display cabinets within specified limits and control the centralised refrigeration systems (packs) to balance the load on the cabinets with the refrigeration capacity of the packs. In recent years the major retailers have also implemented store energy sub-metering and some are using the data available to trend energy consumption and assess the effectiveness of energy conservation measures.

The data available provide the opportunity not only to characterise the various energy consuming processes in the supermarket

but also to relate the consumption patterns to fuel pricing and tariff structures and thereby develop advanced control techniques to minimize maximum electrical demand, energy consumption and fuel costs. It may be possible to perform these tasks on-line by employing adaptive control and diagnostics through Artificial Intelligence techniques.

Energy savings can also be achieved through system integration and pinch technologies to utilise thermal energy, both heating and cooling, generated in some parts of the store, in other parts of the store that require heating or cooling. Other approaches could include on-site Combined Heat and Power generation (CHP) or combined heating power and refrigeration (tri-generation) [35,36].

6. Conclusions

- Investigation of the electrical energy consumption of 2570 retail food stores covering the whole range of retail food outlets from convenience stores to hypermarkets has shown that a wide range of variability exists in the electrical energy intensity of these stores even within the same store category and the same retail food chain. The variability is wider in small sales area stores, convenience stores and supermarkets, where the sales are food dominant.
- The variation of the average electrical energy intensity with sales area of all stores in the sample considered can be described with a power law. If the electrical energy intensity of the stores whose intensity is above the average is reduced to the average through energy conservation measures, 10% electrical energy savings can be achieved, representing 310 GWh per annum for the sample of stores considered or approximately 840 GWh for all the stores of the major retail food chains in the UK. This will produce approximately 355,000 tonnes of CO₂ emissions savings.
- Refrigeration is responsible for a major percentage of the electrical energy consumption of retail food stores ranging from around 25%–30% for hypermarkets to over 60% for food dominant convenience stores. Refrigeration systems are also responsible for direct emissions through refrigerant leakage so in recent years significant effort has been devoted not only to increasing efficiency but to the development of technologies that employ natural refrigerants such as CO₂.
- A number of CO₂ systems mainly of the cascade type has already been installed in the UK. These systems are reported to be performing satisfactorily but no data or comparisons with traditional R404A systems have been published in the open literature. Estimates of capital cost of CO₂ systems compared to R404A vary but are quoted to be between 10% and 30% higher than for comparable R404A systems. These costs are expected to reduce significantly with the wider adoption of CO₂ refrigeration systems. A number of supermarket chains have now expressed commitment to CO₂ so the number of systems is expected to increase significantly in the next few years.
- Irrespective of the type of refrigerant employed, significant energy savings can be achieved by improving the efficiency of the compressors, reducing the pressure ratio in the system, and continuously matching the refrigeration capacity to the load. The pressure ratio can be reduced by employing floating and suction pressure control or heat rejection to the ground.
- Considerable opportunities also exist from refrigeration and HVAC system integration, heat recovery and amplification using heat pumps, demand side management and system diagnostics and local combined heat and power generation and tri-generation.
- Another area that provides significant opportunities for energy savings is the design of more efficient display cabinets.

Research and development areas to be addressed are the reduction of the infiltration rate, reduction of fan and lighting energy consumption, the design of more efficient evaporator coils to increase the evaporating temperature, reduce frosting rates and the implementation of defrost on demand.

Acknowledgements

Work presented in this paper was carried out with financial support from the Department of Environment, Food and Rural Affairs (Defra). The authors would like to acknowledge the support of Defra and the input from the collaborating partners.

References

- [1] DEFRA, Economic Note on UK Grocery Retailing. Department of Environment Food and Rural Affairs, UK, 2006, May 2006, 24 pp.
- [2] S.A. Tassou, Comparison between direct and indirect refrigeration systems in UK supermarkets, Internal Report for IEA Annex, 26, Brunel University (2002), 30 pgs.
- [3] D. van Baxter, IEA Annex 26: Advanced Supermarket Refrigeration/Heat Recovery systems, Final Report Volume 1 – Executive Summary, (2003), 78 pgs. http://web.ornl.gov/sci/engineering_science_technology/Annex26/Annex-26-final-report.pdf
- [4] K. Wand, M. Eisele, Y. Hwang, R. Radermacher, Review of secondary loop refrigeration systems, International Journal of Refrigeration Vol. 33 (Issue 2) (2010) 212–234.
- [5] M. Kauffeld, M. Kawaji, W.P. Egolf, Handbook on Ice Slurries. International Institute of Refrigeration, Paris, 2005, 359 pp.
- [6] I. Bellas, S.A. Tassou, Present and future applications of ice slurries, International Journal of Refrigeration Vol. 28 (Issue 1) (2005) 115–121.
- [7] S. Marinhas, A. Delahaye, L. Fournaison, Solid fraction modelling for CO₂ and CO₂-THF hydrate slurries used as secondary refrigerants, International Journal of Refrigeration Vol. 30 (Issue 5) (2007) 758–766 August 2007.
- [8] H. M-Kim, J. Pettersen, W.C. Bullard, Fundamental process and system design issues in CO₂ vapour compression systems, Progress in Energy and Combustion Science 30 (2004) 119–174.
- [9] J.M. Rhiemeier, J. Harnisch, C. Ters, M. Kauffeld, A. Leisewitch, A comparative assessment of the climate relevance of supermarket refrigeration systems and equipment, Environmental Research of the Federal Ministry of the Environment, Nature Conservation and Nuclear Safety, Research Report 206 44 300 (2009), <http://www.umweltbundesamt.de>
- [10] S. Sawalha, J. Rogstam, P-O. Nilsson, Laboratory Tests of NH₃/CO₂ Cascade System for Supermarket Refrigeration, Proceedings of IIR International Conference “Commercial Refrigeration”, Paper 26 on CD ROM, Vicenza, Italy, 30–31 August 2005, pp. 15–21.
- [11] G.K. Christensen, P. Bertilsen, Refrigeration systems in supermarkets with propane and CO₂ – energy consumption and economy. <http://www.aiarh.org.au/downloads/2004-02-02.pdf> (2004).
- [12] G.J. van Riessen, NH₃/CO₂ Supermarket Refrigeration System with CO₂ in the Cooling and Freezing Section - Technical, Energetic and Economical Issues, 2004. www.tno-refrigeration.com/mediapool/48/485045/data/CO2_supermarket.pdf 7 pp.
- [13] S. Haaf, B. Heinbokel, A. Gerneman, First CO₂ Refrigeration System for Medium and Low-Temperature Refrigeration at Swiss Megastore, (2005) http://www.linde-kaeltetechnik.de/uploads/media/CO2_Sonderdruck_deutsch.pdf.
- [14] RAC, (Refrigeration and Air Conditioning Magazine, A new Era, A transcritical CO₂ system developed by Tesco and Star is set to change the face of supermarket refrigeration, Nov. 2009, pp. 22–23.
- [15] S. Da Ros, Transcritical CO₂ systems: a case study into the latest evolution, www.centrogalileo.it/nuovaPA/.../EPTA%20Group.pdf.
- [16] Danfoss, Transcritical CO₂ system in a small supermarket, 2008, 8 pp
- [17] Y.T. Ge, S.A. Tassou, Mathematical modelling of supermarket refrigeration systems for design, energy prediction and control. Proceedings of the Institution of Mechanical Engineers Part a, Journal of Power and Energy 214 (A2) (2000) 101–114.
- [18] D. Datta, R. Watkins, S.A. Tassou, A. Hadaway, A. Maki, Formal Based Methodologies for the Design of Stand Alone Display Cabinets. Final report to DEFRA for project AFM144, November 2005, 177 pp.
- [19] D. Stribling, S.A. Tassou, D. Marriott, A two-Dimensional CFD Model of display case, ASHRAE Transactions Research Vol. 103 (1997) 88–95 Part 1.
- [20] N.J. Smale, J. Moureh, G. Cortella, A review of numerical models of airflow in refrigerated food applications, International Journal of Refrigeration vol. 29 (6) (2006) 911–930.
- [21] M. Foster, J. Madge, J. Evans, The use of CFD to improve the performance of a chilled multi-deck retail display cabinet, International Journal of Refrigeration Vol. 28 (Issue 5) (2005) 698–705.
- [22] R. Faramzi, Investigation of Air Cutians in Open Refrigerated Display Cases – Project Overview. Presentation at PAC Meeting, Dallas, Texas, January 2007, 29.
- [23] D. Datta, R. Watkins, S.A. Tassou, Effect of night blinds on open integral display cabinets, Proceedings of 3rd International Conference on Heat powered cycles HPC 2004, on CD-ROM, Larnaca, Cyprus, 10–13 October 2004.
- [24] S.M. van Der Sluis, Glass covers on refrigerated display cabinets, TNO report, nr 034.68803, (2007) 11 pgs.
- [25] A. Karas, C. Zabrowski, D. Fisher, GE ECM Evaporator Fan Motor Energy Monitoring, FSTC Report 5011.05.13, Fisher-Nickel Inc., California, (2006) <http://www.fishnick.com.pablications>, 5 pp.
- [26] D. Bullard, R. Chandrasekharan, Analysis and design Tradeoffs for display case evaporators, Report prepared for Oak Ridge National Laboratory for contract US department of energy DE-AC05-00OR22725 (2004), 98 pgs. www.ornl.gov/sci/btc/pdfs/Display_case_evaporator_model_report_TM-2004-157.pdf
- [27] S.A. Tassou, D. Datta, D. Marriott, Frost formation and defrost control parameters for open multideck refrigerated food display cabinets, Proceedings of the Institution of Mechanical Engineers, Professional Engineering Publishing Vol. 215 (No. 2) (2001) 213–222.
- [28] JTL Systems Ltd, Defrost on demand system, Carbon Trust Grant Funded Projects (2005). www.thecarbontrust.co.uk/.../successfulprojects.htm.
- [29] J.M.W. Lawrence, D. Gibson, Energy use in commercial refrigeration, Proceedings of the Institute of Refrigeration 5 (1) (2010) 5–11 2009–10.
- [30] S.A. Tassou, W. Xiang, Investigation of Methods to Improve Retail Store Environment Using CFD pgs 143–166. in: D.-W. Sun (Ed.), Computational Fluid Dynamics in Food Processing. CRC Press, Florida USA, 2007 ISBN-13:978-0-8493-9886-3.
- [31] A. Campbell, R. Oliver, Building services for low carbon supermarkets to, Proc. Inst. R 3 (1) (2009) 3–8 2009–10.
- [32] S.A. Tassou, Potential of solar energy in food Manufacture, Distribution and Retail, DEFRA, Final Report, AC0405 (2006), 25 pp.
- [33] N. Narendran, J. Brons, J. Taylor, Energy efficient lighting alternative for commercial refrigeration, Report prepared for the New York State energy research and development Authority, Ransselaer Polytechnic Institute, (2006), 41 pgs. <http://www.lrc.rpi.edu/programs/solidstate/pdf/FreezerLighting-FinalReport.pdf>.
- [34] GE Consumer Industrial, Press Release, Wal-Mart Uses GE LED Refrigerated Display Lighting, (2006), <http://home.businesswire.com/portal/site/GE>.
- [35] G.G. Maidment, R.M. Tozer, Combined cooling heat and power in supermarkets, Applied Thermal Engineering Volume 22 (2002) 653–665 Issue 6.
- [36] N. Sugiarta, S.A. Tassou, I. Chaer, D. Marriott, Trigeneration in food retail-an energetic, economic and environmental evaluation for a supermarket application, in print, Applied Thermal Engineering Volume 29 (Issue 13) (2009) 2624–2632.